

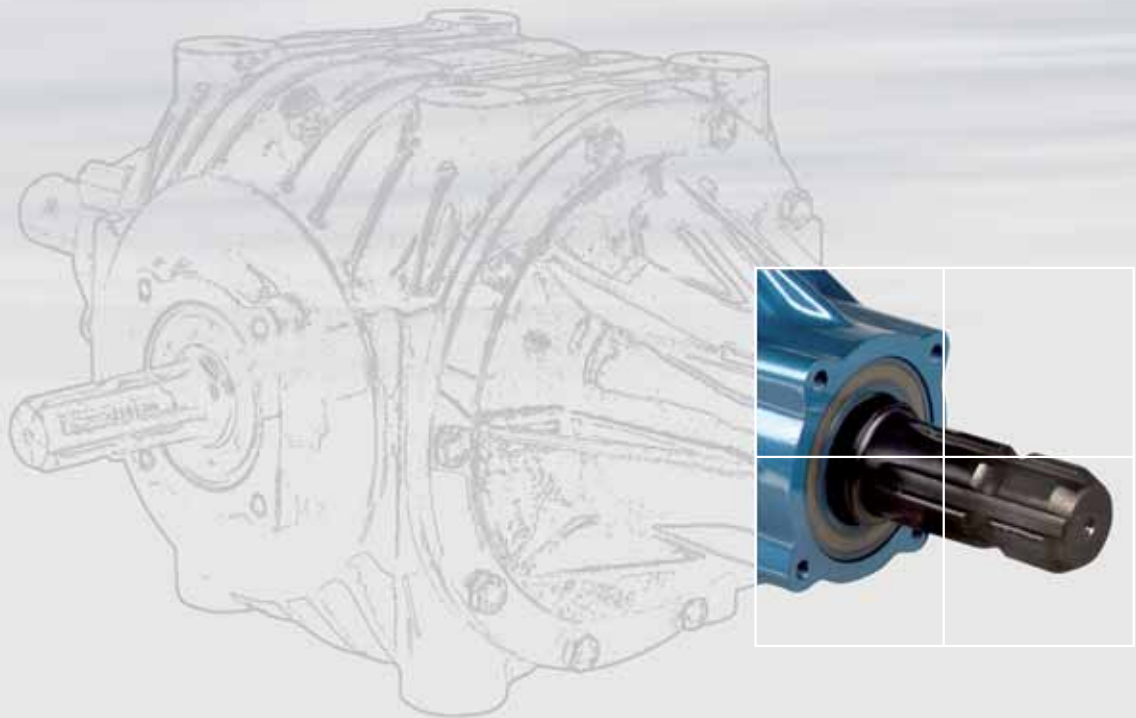

comer industries

# Gearboxes





pag.	
2	Profilo
4	Tipo macchina
6	Scatole di ingranaggi ad assi paralleli
8	Scatole di ingranaggi ad assi ortogonali
19	Giroandanatori
20	Cambi
25	Barre falcianti
27	Applicazioni speciali
29	Centro Ricerche di Meccatronica

# Gearboxes

Gearboxes

page	
2	Profile
4	Machine type
6	Parallel axes gearboxes
8	Right angle gearboxes
19	Rotary rakes
20	Speed change gears
25	Cutter bars
27	Special applications
29	Mechatronics R&D centre





# Profilo

Profile

Comer Industries è una società di Meccatronica che progetta, produce e commercializza sistemi avanzati per la trasmissione di potenza. L'azienda propone una linea completa di trasmissioni meccaniche, idrostatiche e servizi di ingegneria, di logistica e di Information Technology per l'industria delle macchine operatrici agricole ed industriali.

L'azienda opera da oltre 35 anni nei principali paesi del mondo, in particolare in Europa e Nord America, dove è partner dei maggiori gruppi agricoli ed industriali del settore, riunendo le esperienze e le competenze di diverse specializzazioni produttive.

La linea di produzione GEARBOXES & DRIVESHAFTS comprende scatole di ingranaggi (cambi di velocità; riduttori, moltiplicatori e rinvii sia angolari che ad assi paralleli), alberi cardanici e dispositivi di sicurezza, destinati all'impiego su macchine operatrici agricole.

Le trasmissioni della linea GEARBOXES & DRIVESHAFTS sono altamente personalizzate, la gamma è versatile ed evoluta, e l'ampia conoscenza delle applicazioni agricole unita all'elevata capacità progettuale consentono di rispondere alle esigenze del cliente con l'innovazione continua, la qualità e l'offerta di un servizio completo.



*Comer Industries is a Mechatronics company that designs, manufactures and sells advanced engineering solutions for power transmission. It offers a full line of mechanical and hydrostatic transmissions, as well as integrated drive systems, together with knowledge and service-based ICT activities for agricultural and industrial equipments.*

*For more than 35 years Comer Industries operates in the main countries all over the world, particularly in Europe and North America, where it has become the partner of the leading industrial and agricultural machinery OEMs, combining the expertise of a variety of manufacturing activities and business organization.*

*The GEARBOXES & DRIVESHAFTS product line is divided into gearboxes (speed change gears, parallel and right angle shaft speed increasers and reducers), driveshafts and safety devices mainly employed on agricultural equipments.*

*The GEARBOXES & DRIVESHAFTS transmissions are highly customized and available in many advanced versions. Application engineering and high design capability allow to solve any customer's problems, granting continuous improvement, quality and total service.*

# Gearboxes







# Tipo Macchina

Machine type

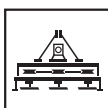

## APPLICAZIONI VARIE - MISCELLANEOUS APPLICATIONS

	0.00
<b>Applicazioni varie</b> <i>Miscellaneous applications</i>	

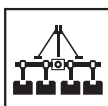

## MACCHINE PER LA PREPARAZIONE DEL TERRENO - MACHINERY FOR LAND PREPARATION

	1.01		1.02		1.03		1.04
<b>Trinciastocchi</b> <i>Flail mowers</i>		<b>Falciadistruggierba</b> <i>Rotary mowers</i>		<b>Decespugliatrici</b> <i>Rotary cutters</i>		<b>Spandiletame</b> <i>Manure spreaders</i>	





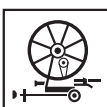

## MACCHINE PER LA LAVORAZIONE DEL TERRENO - MACHINERY FOR SOIL TILLAGE

	2.01		2.02		2.03		2.04
<b>Zappatrici - Fresatrici</b> <i>Rotary tillers</i>		<b>Zappatrici multiple</b> <i>Multiple rotary tillers</i>		<b>Ercipi rotanti</b> <i>Vertical tillers</i>		<b>Trivelle</b> <i>Post hole diggers</i>	

## MACCHINE PER IL TRATTAMENTO DELLE COLTURE - MACHINERY FOR PLANT AND CROP TREATMENT

	3.01		3.02		3.03		3.04
<b>Atomizzatori</b> <i>Sprayers</i>		<b>Spandiconcime</b> <i>Fertilizer spreaders</i>		<b>Pompe centrifughe per irrigazione</b> <i>Centrifugal pumps for irrigation</i>		<b>Irrigatori a bobina</b> <i>Irrigation reels</i>	

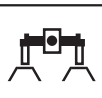

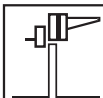



**MACCHINE PER LA RACCOLTA, TRASFORMAZIONE E DISTRIBUZIONE DEL FORAGGIO**  
**MACHINERY FOR HARVESTING, PROCESSING AND DISTRIBUTION OF FORAGE**











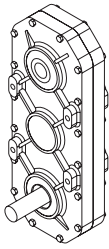

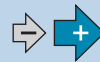

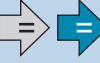

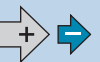
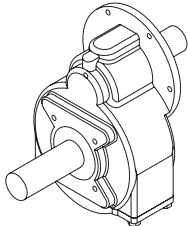







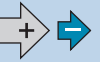
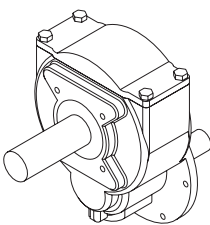





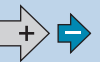

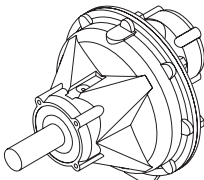







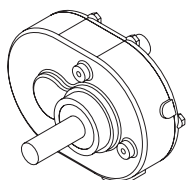

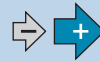

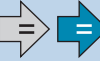

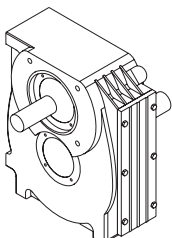

 4.01	 4.02	 4.03	 4.04
Falciatrici rotative <i>Rotary mowers</i>	Giroandanatori <i>Rotary rakes</i>	Carri autocaricanti <i>Self loading trailers</i>	Presse raccogliatrici <i>Balers</i>
 4.05	 4.06	 4.07	
Spandifieno rotativi <i>Rotary tedders</i>	Desilatori <i>Silo unloaders</i>	Molini a martelli <i>Hammer mills</i>	

**MACCHINE PER SERVIZI AUSILIARI - MACHINERY FOR AUXILIARY SERVICES**

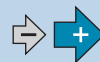

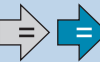







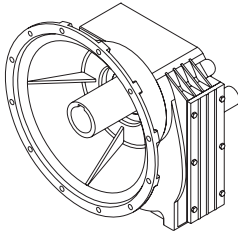

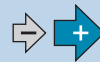



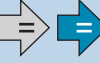



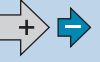

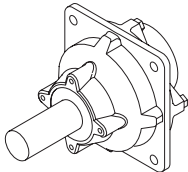

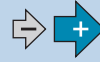







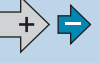

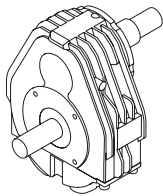

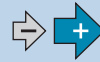









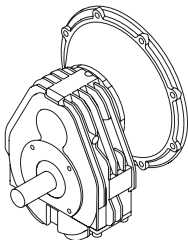













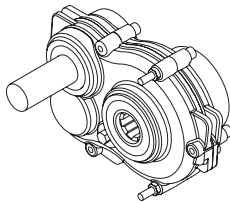





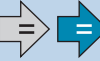



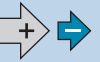

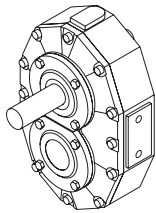

 5.01	 5.02	 5.03	
Gruppi elettrogeni <i>P.T.O. generators</i>	Seghe circolari - a nastro <i>Circular saws - Belt saws</i>	Pompe trituratrici per liquami <i>Lagoon pumps</i>	



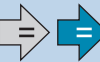



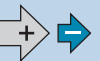



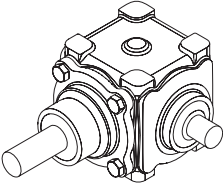

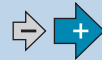







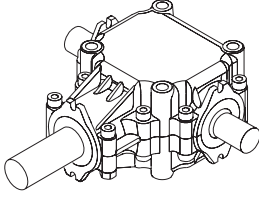









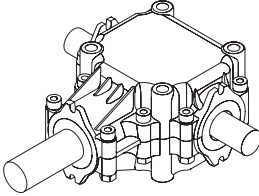







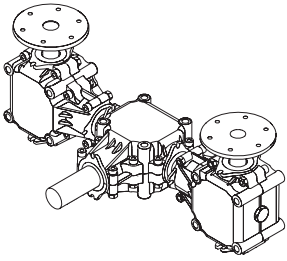







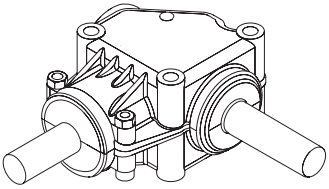

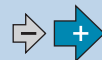



**Legenda - Legend**

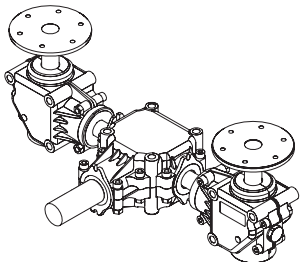

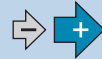







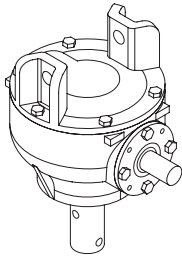

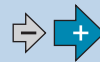

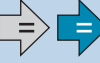

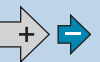
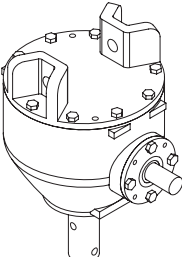

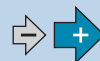

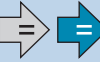



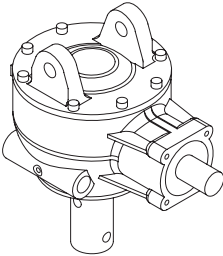

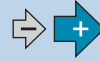



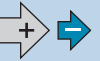
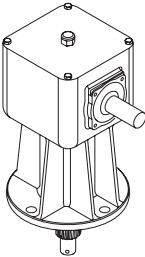

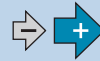



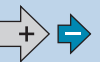
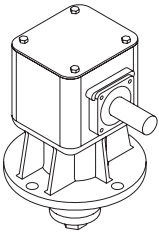





	Potenza in entrata <i>Input power</i>		Moltiplicatore <i>Speed increasing unit</i>
	Momento torcente in uscita <i>Output torque</i>		Rinvio <i>1:1 ratio</i>
	Giri in entrata <i>Input r.p.m.</i>		Riduttore <i>Reduction gear unit</i>

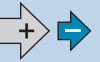
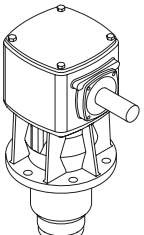







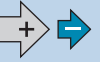

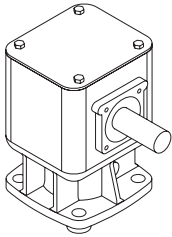





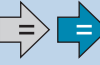

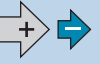
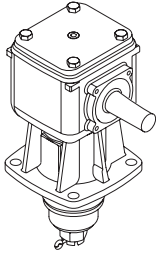

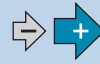

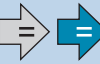

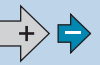
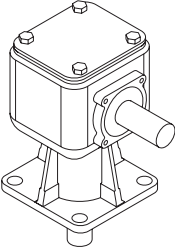

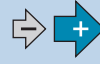

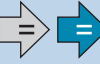

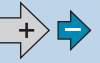
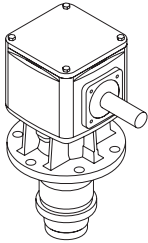





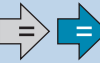

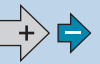
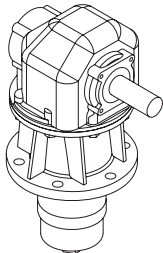

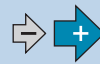
A-16A									
		[HP] [kW]	85.1 62.6			-		<input type="checkbox"/>	<input type="checkbox"/>
		[daNm]	107.1			1.00		<input type="checkbox"/>	<input type="checkbox"/>
		[rpm]	540			-		<input type="checkbox"/>	<input type="checkbox"/>
A-1A									
		[HP] [kW]	5.0 - 16.0 3.7 - 11.8			7.80		<input type="checkbox"/>	<input type="checkbox"/>
		[daNm]	2.5 - 49.1			-		<input type="checkbox"/>	<input type="checkbox"/>
		[rpm]	540			7.80		<input type="checkbox"/>	<input type="checkbox"/>
A-1B									
		[HP] [kW]	13.0 9.6			7.00	<input type="checkbox"/>	<input type="checkbox"/>	<input type="checkbox"/>
		[daNm]	2.9			-		<input type="checkbox"/>	<input type="checkbox"/>
		[rpm]	429			-		<input type="checkbox"/>	
A-20A									
		[HP] [kW]	75.0 55.2			1.88		<input type="checkbox"/>	<input type="checkbox"/>
		[daNm]	50.3 - 96.0			-		<input type="checkbox"/>	<input type="checkbox"/>
		[rpm]	540			1.88		<input type="checkbox"/>	<input type="checkbox"/>
A-3A									
		[HP] [kW]	9.0 - 45.0 6.6 - 33.1			1.23 - 5.90		<input type="checkbox"/>	<input type="checkbox"/>
		[daNm]	4.9 - 62.5			1.00			
		[rpm]	540			1.23 - 5.27			
A-4A									
		[HP] [kW]	12.0 - 90.0 8.8 - 64.0			1.48 - 7.00		<input type="checkbox"/>	<input type="checkbox"/>
		[daNm]	10.8 - 109.4			1.00		<input type="checkbox"/>	
		[rpm]	540			1.48 - 7.00			<input type="checkbox"/>

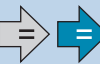

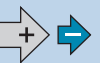
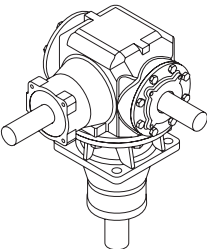

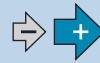

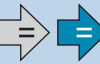

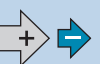

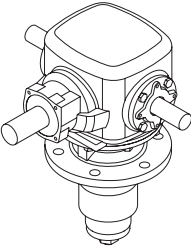

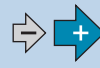



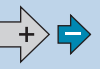
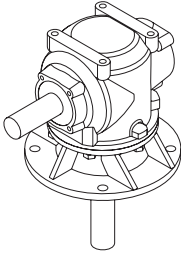

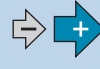

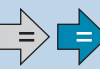

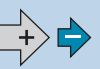
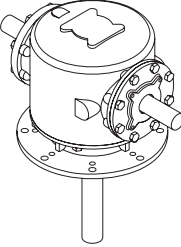



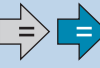

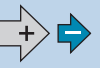
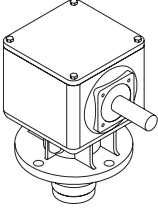

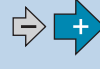

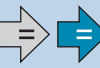

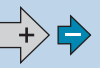
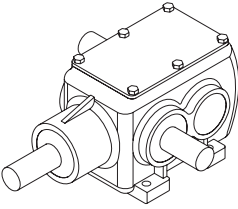

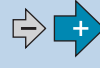

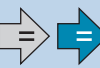

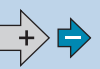
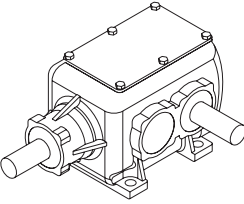

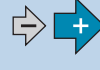

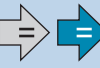

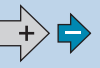

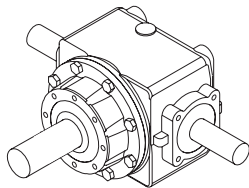

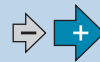

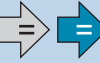

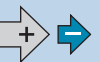
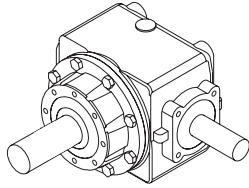

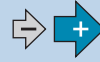



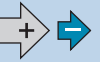
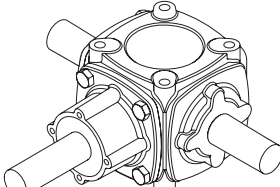

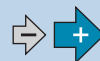



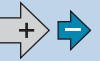
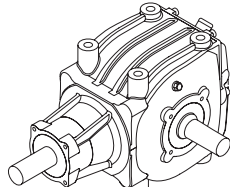







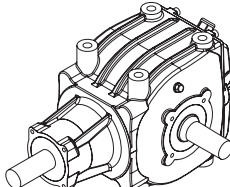





A-4F									
		[HP] [kW]	74.7 55.0			3.80			
		[daNm]	34.0			-			
		[rpm]	395			-			
A-623A									
		[HP] [kW]	10.1 - 14.9 7.4 - 11.0			1.60			
		[daNm]	11.8 - 20.1			-			
		[rpm]	540			1.60			
A-624A									
		[HP] [kW]	10.1 - 42.9 7.4 - 31.6			3.50 - 6.90			
		[daNm]	6.3 - 87.0			-			
		[rpm]	540			3.50 - 6.90			
A-624C									
		[HP] [kW]	29.9 - 40.8 22.0 - 30.0			3.50 - 6.90			
		[daNm]	6.8 - 18.5			-			
		[rpm]	429 - 435			-			
A-647A									
		[HP] [kW]	14.9 11.0			-			
		[daNm]	56.9			-			
		[rpm]	540			3.01			
MR-90									
		[HP] [kW]	42.9 - 87.0 31.6 - 64.0			1.90			
		[daNm]	57.7 - 107.1			1.00			
		[rpm]	540			1.90			

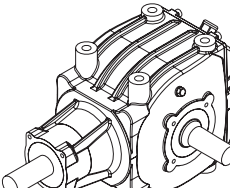



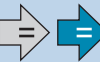





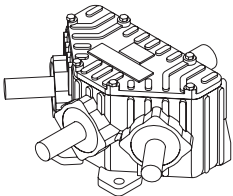

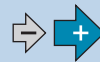



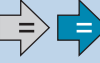

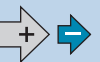
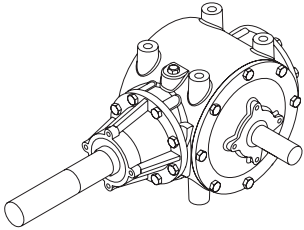

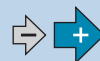

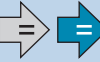

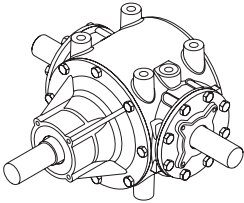

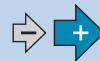



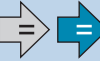

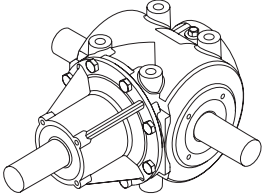





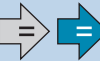

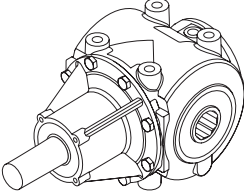





L-5A									
		[HP] [kW]	3.9 - 14.9 2.9 - 11.0			1.35 - 3.00			
		[daNm]	3.0 - 22.7			1.00			
		[rpm]	540			1.35 - 2.78			
L-25A									
		[HP] [kW]	3.0 - 14.9 2.2 - 11.0			1.35 - 2.91			
		[daNm]	3.1 - 22.7			1.00			
		[rpm]	540			1.35 - 3.30			
L-25B									
		[HP] [kW]	13.5 - 14.9 9.9 - 11.0			1.35			
		[daNm]	12.6 - 18.9			1.00			
		[rpm]	540			-			
L-25C									
		[HP] [kW]	14.9 11.0			1.35			
		[daNm]	12.6			-			
		[rpm]	540			-			
L-150B									
		[HP] [kW]	11.0 8.1			-			
		[daNm]	13.8			1.00			
		[rpm]	540			-			
L-150C									
		[HP] [kW]	13.5 9.9			1.35			
		[daNm]	12.6			-			
		[rpm]	540			-			

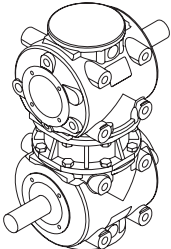

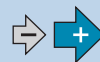

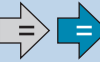





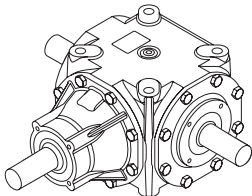

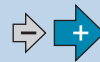



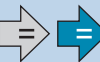



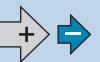

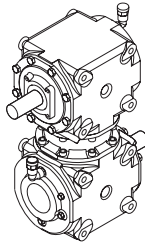

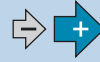



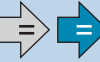



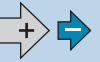

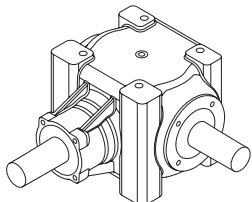













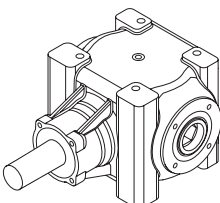













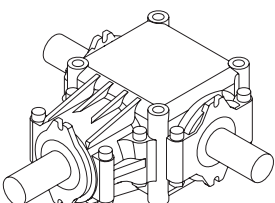













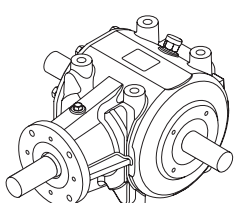



L-196J									
		[HP] [kW]	25.0 18.4			-	<input type="checkbox"/>	<input type="checkbox"/>	
		[daNm]	105.4			-		<input type="checkbox"/>	<input type="checkbox"/>
		[rpm]	540			3.18	<input type="checkbox"/>	<input type="checkbox"/>	<input type="checkbox"/>
L-212J									
		[HP] [kW]	29.9 22.0			-	<input type="checkbox"/>	<input type="checkbox"/>	
		[daNm]	159.1			-		<input type="checkbox"/>	<input type="checkbox"/>
		[rpm]	540			4.00	<input type="checkbox"/>	<input type="checkbox"/>	<input type="checkbox"/>
L-216J									
		[HP] [kW]	22.0 16.2			-	<input type="checkbox"/>	<input type="checkbox"/>	
		[daNm]	79.5			-		<input type="checkbox"/>	<input type="checkbox"/>
		[rpm]	540			3.00	<input type="checkbox"/>	<input type="checkbox"/>	<input type="checkbox"/>
LF-139A									
		[HP] [kW]	70.0 - 89.9 51.5 - 66.2			1.20 - 1.93	<input type="checkbox"/>		
		[daNm]	45.7 - 113.4			1.00	<input type="checkbox"/>	<input type="checkbox"/>	
		[rpm]	540			-	<input type="checkbox"/>	<input type="checkbox"/>	
LF-140A									
		[HP] [kW]	60.1 - 64.9 44.2 - 47.8			1.27 - 1.93	<input type="checkbox"/>		
		[daNm]	39.2 - 65.8			-	<input type="checkbox"/>	<input type="checkbox"/>	
		[rpm]	540			-	<input type="checkbox"/>	<input type="checkbox"/>	
LF-149B									
		[HP] [kW]	74.9 - 89.9 55.1 - 66.2			1.20 - 1.50	<input type="checkbox"/>		
		[daNm]	61.2 - 64.3			1.00	<input type="checkbox"/>	<input type="checkbox"/>	
		[rpm]	540			-	<input type="checkbox"/>	<input type="checkbox"/>	

LF-151A									
		[HP] [kW]	45.0 - 48.0 33.1 - 35.3			2.54 - 3.00	<input type="checkbox"/>		
		[daNm]	18.9 - 23.8			-	<input type="checkbox"/>	<input type="checkbox"/>	
		[rpm]	540			-	<input type="checkbox"/>	<input type="checkbox"/>	
LF-205J									
		[HP] [kW]	30.0 - 39.9 22.1 - 29.4			1.47 - 1.92	<input type="checkbox"/>		
		[daNm]	19.7 - 34.3			-	<input type="checkbox"/>	<input type="checkbox"/>	
		[rpm]	540			-	<input type="checkbox"/>	<input type="checkbox"/>	
LF-211J									
		[HP] [kW]	20.0 - 21.1 14.7 - 15.5			2.50 - 2.83	<input type="checkbox"/>		
		[daNm]	8.9 - 12.2			-	<input type="checkbox"/>	<input type="checkbox"/>	
		[rpm]	540			-	<input type="checkbox"/>	<input type="checkbox"/>	
LF-227J									
		[HP] [kW]	74.9 55.1			1.22 - 1.83	<input type="checkbox"/>		
		[daNm]	51.7 - 77.5			1.00	<input type="checkbox"/>	<input type="checkbox"/>	
		[rpm]	540			1.22	<input type="checkbox"/>	<input type="checkbox"/>	
LF-32A									
		[HP] [kW]	60.1 44.2			1.50 - 1.93	<input type="checkbox"/>		
		[daNm]	39.2 - 50.4			1.00	<input type="checkbox"/>	<input type="checkbox"/>	
		[rpm]	540			-	<input type="checkbox"/>	<input type="checkbox"/>	
TF-26A									
		[HP] [kW]	89.9 66.2			1.85	<input type="checkbox"/>		
		[daNm]	61.3			-	<input type="checkbox"/>	<input type="checkbox"/>	
		[rpm]	540			-	<input type="checkbox"/>	<input type="checkbox"/>	











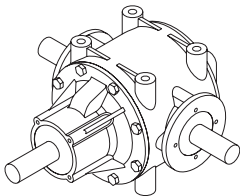

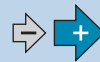



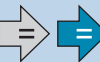

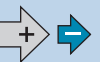
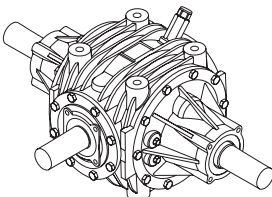

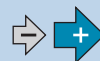

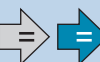

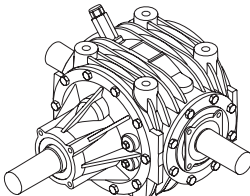









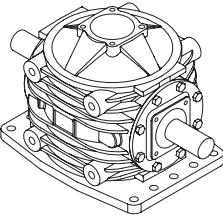







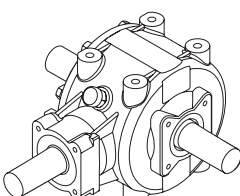







TF-285B									
		[HP] [kW]	114.9 84.6			1.86			
		[daNm]	77.9			-			
		[rpm]	540			-			
TV-21B									
		[HP] [kW]	22.0 16.2			-			
		[daNm]	53.2			-			
		[rpm]	540			1.92			
TV-274A									
		[HP] [kW]	80.0 58.9			-			
		[daNm]	194.7			-			
		[rpm]	540			1.93			
U10-100J									
		[HP] [kW]	101.4 74.6			1.22 - 1.83			
		[daNm]	68.6 - 103.0			-			
		[rpm]	540			1.22 - 1.46			
N-2A									
		[HP] [kW]	31.9 23.5			-			
		[daNm]	-			1.00			
		[rpm]	540			5.67			
N-698A									
		[HP] [kW]	54.9 40.4			-			
		[daNm]	-			1.00			
		[rpm]	540			5.70			

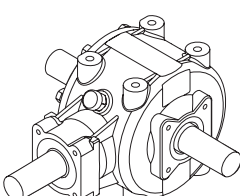









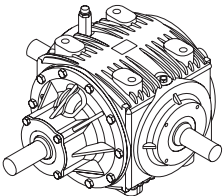

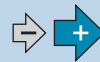



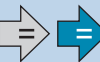



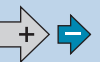

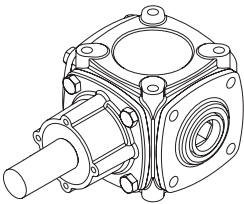

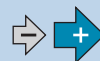



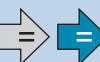



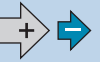

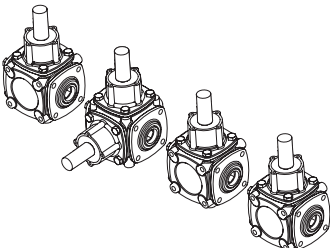









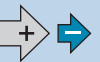

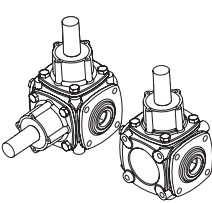













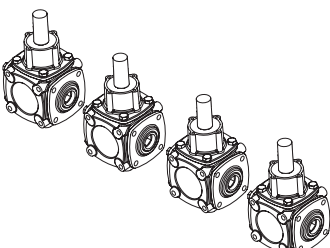













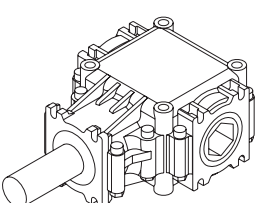



LV-221A									
		[HP] [kW]	44.8 33.0			-	<input type="checkbox"/>	<input type="checkbox"/>	
		[daNm]	101.1			-		<input type="checkbox"/>	<input type="checkbox"/>
		[rpm]	540			1.78	<input type="checkbox"/>	<input type="checkbox"/>	<input type="checkbox"/>
LZ-221F									
		[HP] [kW]	44.8 33.0			-	<input type="checkbox"/>	<input type="checkbox"/>	
		[daNm]	101.0			-		<input type="checkbox"/>	<input type="checkbox"/>
		[rpm]	540			1.78	<input type="checkbox"/>	<input type="checkbox"/>	<input type="checkbox"/>
T-19A									
		[HP] [kW]	5.00 - 33.0 3.7 - 24.3			1.46 - 2.91		<input type="checkbox"/>	
		[daNm]	4.5 - 41.6			1.00	<input type="checkbox"/>	<input type="checkbox"/>	
		[rpm]	540			1.46 - 2.91	<input type="checkbox"/>	<input type="checkbox"/>	
T-22A									
		[HP] [kW]	20.0 - 98.0 14.7 - 72.1			1.93 - 6.14		<input type="checkbox"/>	
		[daNm]	10.2 - 200.5			-	<input type="checkbox"/>	<input type="checkbox"/>	
		[rpm]	540			1.93 - 6.14	<input type="checkbox"/>	<input type="checkbox"/>	
TB-22C									
		[HP] [kW]	53.9 - 82.1 39.7 - 60.4			-	<input type="checkbox"/>	<input type="checkbox"/>	
		[daNm]	165.4 - 199.5			-		<input type="checkbox"/>	<input type="checkbox"/>
		[rpm]	540			1.93 - 2.43	<input type="checkbox"/>	<input type="checkbox"/>	
TV-22D									
		[HP] [kW]	85.1 - 98.0 62.6 - 72.1			1.93 - 3.00	<input type="checkbox"/>	<input type="checkbox"/>	
		[daNm]	35.7 - 64.0			-	<input type="checkbox"/>	<input type="checkbox"/>	
		[rpm]	540			-	<input type="checkbox"/>		











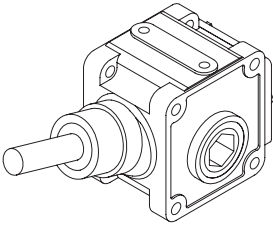

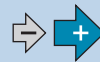

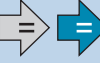

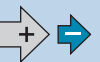

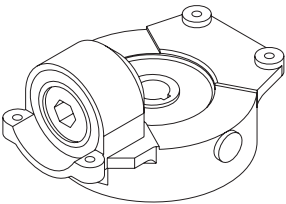



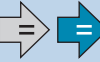

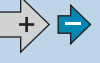

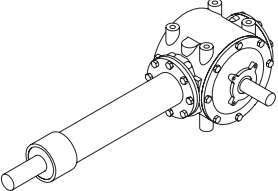





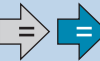

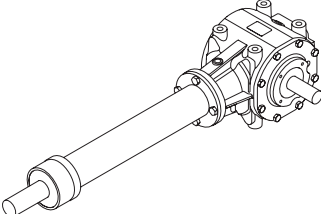





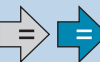

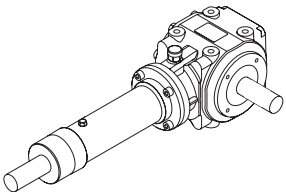

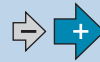
T-25A									
		[HP] [kW]	119.6 88.0			1.15			
		[daNm]	110.9			1.00			
		[rpm]	540			-			
T-269A									
		[HP] [kW]	89.9 - 105.0 66.2 - 77.3			1.42			
		[daNm]	93.2 - 161.1			1.00			
		[rpm]	540			1.42			
T-269B									
		[HP] [kW]	53.0 - 105.0 39.0 - 77.3			1.42 - 3.00			
		[daNm]	35.7 - 200.5			-			
		[rpm]	540			1.42 - 3.00			
T-278A									
		[HP] [kW]	28.9 - 55.0 21.3 - 40.5			1.60 - 2.91			
		[daNm]	19.5 - 108.9			1.00			
		[rpm]	540			1.60 - 2.91			
TB-278C									
		[HP] [kW]	45.0 - 50.0 33.1 - 36.8			-			
		[daNm]	100.8 - 108.9			-			
		[rpm]	540			1.60 - 1.92			
T-278D									
		[HP] [kW]	60.1 44.2			1.35			
		[daNm]	56.0 - 75.6			1.00			
		[rpm]	540			-			



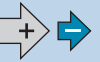
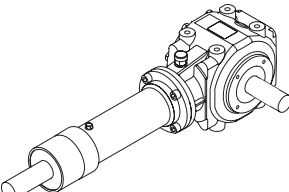

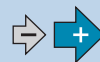



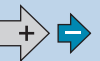

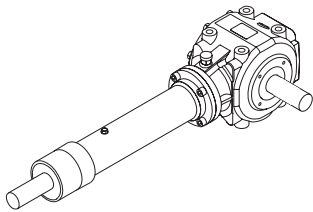

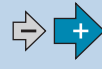



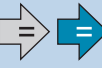





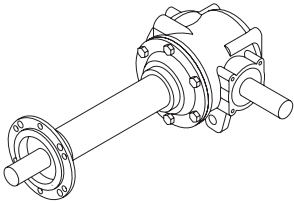

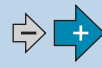



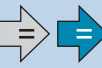





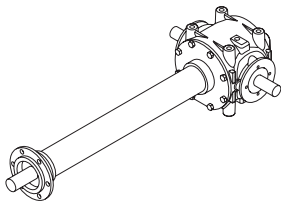

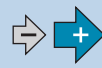



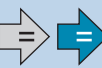





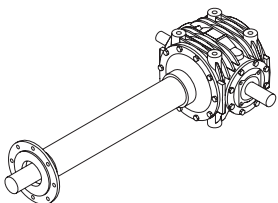

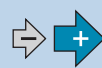
T-279A									
		[HP] [kW]	80.0 - 100.0 58.9 - 73.6			1.35 - 1.50			
		[daNm]	75.6 - 153.2			1.00			
		[rpm]	540			1.35 - 1.50			
T-279D									
		[HP] [kW]	85.1 - 100.0 62.6 - 73.6			1.35			
		[daNm]	79.4 - 126.0			1.00			
		[rpm]	540			-			
T-27A									
		[HP] [kW]	20.5 - 55.0 15.1 - 40.5			1.44 - 1.92			
		[daNm]	19.7 - 73.6			1.00			
		[rpm]	540			1.46 - 1.92			
TB-27C									
		[HP] [kW]	22.0 - 55.0 16.2 - 40.5			-			
		[daNm]	53.2 - 73.6			1.00			
		[rpm]	540			1.46 - 1.92			
T-281A									
		[HP] [kW]	5.0 - 23.0 3.7 - 16.9			1.46 - 2.91			
		[daNm]	4.7 - 29.4			1.00			
		[rpm]	540			1.46 - 2.91			
T-290A									
		[HP] [kW]	44.8 - 94.8 33.0 - 69.8			3.00 - 1.47			
		[daNm]	32.8 - 175.9			1.00			
		[rpm]	540			3.00 - 1.47			



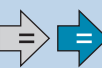







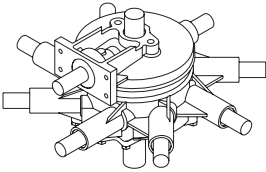

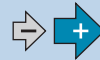





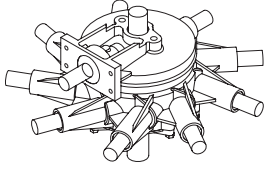







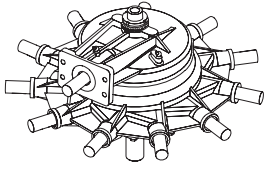







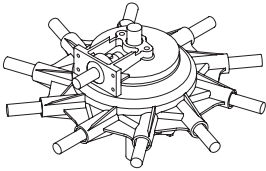







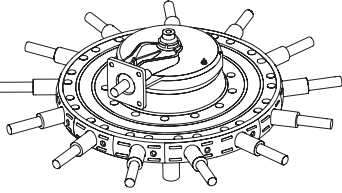







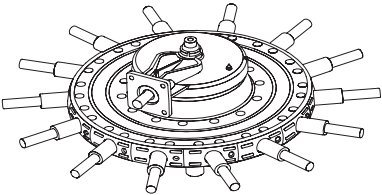









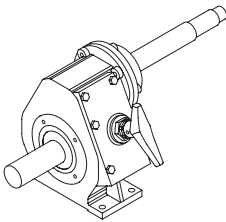

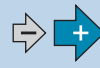



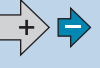
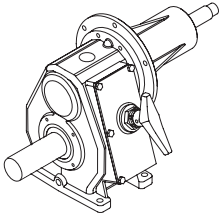

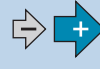

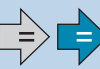

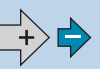
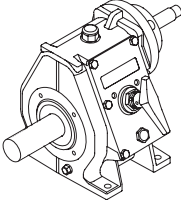



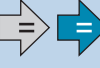

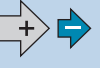
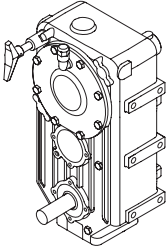

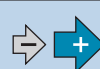





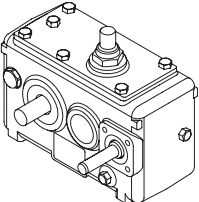

T-292B										
		[HP] [kW]	80.0 - 89.9 58.9 - 66.2			1.47 - 1.86				
		[daNm]	54.2 - 105.9			1.00				
		[rpm]	540			-				
T-301A										
		[HP] [kW]	104.9 - 139.8 77.2 - 102.9			1.35 - 1.93				
		[daNm]	71.9 - 255.5			-				
		[rpm]	540			1.35 - 1.93				
T-301B										
		[HP] [kW]	104.9 - 192.8 77.2 - 141.9			1.35 - 1.93				
		[daNm]	51.1 - 255.5			1.00				
		[rpm]	540 - 1000			1.35 - 1.93				
TV-301A										
		[HP] [kW]	99.9 73.5			-				
		[daNm]	252.0 - 321.0			-				
		[rpm]	540			1.93 - 2.42				
T-304A										
		[HP] [kW]	13.5 - 54.9 9.9 - 40.4			1.93 - 5.33				
		[daNm]	6.3 - 94.5			-				
		[rpm]	540			1.93 - 5.33				
T-304H										
		[HP] [kW]	25.0 18.4			-				
		[daNm]	94.5			-				
		[rpm]	540			3.00				

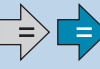

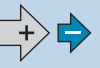
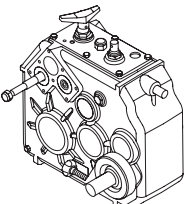

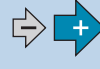

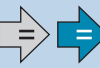

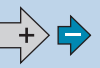

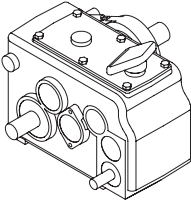

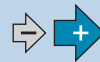

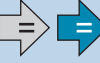

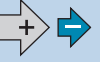
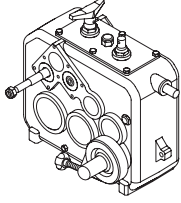

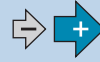



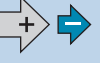
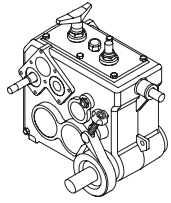

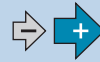





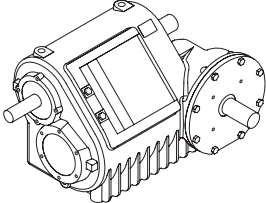







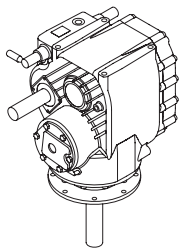

T-331A								
		[HP] [kW]	109.9 - 298.9 80.9 - 220.0			1.35 - 3.27		
		[daNm]	143.8 - 435.5			1.00		
		[rpm]	540			1.35 - 3.27		
TB-19C								
		[HP] [kW]	14.9 - 28.0 11.0 - 20.6			1.46		
		[daNm]	24.1 - 42.3			-		
		[rpm]	540			1.46 - 1.85		
TB-19H								
		[HP] [kW]	20.0 - 23.0 14.7 - 16.9			1.46		
		[daNm]	17.2			1.00		
		[rpm]	540			1.46		
TB-19I								
		[HP] [kW]	20.0 - 23.0 14.7 - 16.9			1.46		
		[daNm]	17.2			1.00		
		[rpm]	540			1.46		
TB-19L								
		[HP] [kW]	23.0 16.9			-		
		[daNm]	29.0			1.00		
		[rpm]	540			-		
TB-281B/C								
		[HP] [kW]	14.9 - 23.0 11.0 - 16.9			-		
		[daNm]	33.1 - 42.3			-		
		[rpm]	540			1.46 - 1.84		

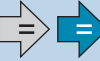
TB-318J								
		[HP] [kW]	27.2 20.0			-	<input type="checkbox"/>	<input type="checkbox"/>
		[daNm]	-			-	<input type="checkbox"/>	<input type="checkbox"/>
		[rpm]	540			1.77		<input type="checkbox"/>
TB-319J								
		[HP] [kW]	9.0 6.6			-	<input type="checkbox"/>	<input type="checkbox"/>
		[daNm]	-			-	<input type="checkbox"/>	<input type="checkbox"/>
		[rpm]	300			2.00		<input type="checkbox"/>
TL-269E								
		[HP] [kW]	89.9 - 110.1 66.2 - 81.0			1.42 - 2.42	<input type="checkbox"/>	
		[daNm]	46.9 - 97.6			-	<input type="checkbox"/>	<input type="checkbox"/>
		[rpm]	540			-	<input type="checkbox"/>	<input type="checkbox"/>
TL-290D								
		[HP] [kW]	77.9 - 129.9 57.3 - 95.6			1.47 - 3.00	<input type="checkbox"/>	
		[daNm]	32.8 - 60.2			-	<input type="checkbox"/>	<input type="checkbox"/>
		[rpm]	540			-	<input type="checkbox"/>	<input type="checkbox"/>
TL-310D								
		[HP] [kW]	29.9 - 59.0 22.0 - 43.4			1.60 - 3.00	<input type="checkbox"/>	
		[daNm]	12.6 - 26.1			-	<input type="checkbox"/>	<input type="checkbox"/>
		[rpm]	540			-	<input type="checkbox"/>	<input type="checkbox"/>
TL-311D								
		[HP] [kW]	49.9 - 77.9 36.7 - 57.3			1.60 - 3.00	<input type="checkbox"/>	
		[daNm]	21.0 - 35.9			-	<input type="checkbox"/>	<input type="checkbox"/>
		[rpm]	540			-	<input type="checkbox"/>	<input type="checkbox"/>

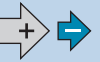
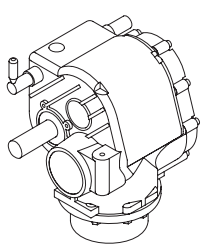
TL-312D								
		[HP] [kW]	62.0 - 103.9 45.6 - 76.5			1.60 - 3.00		
		[daNm]	26.1 - 47.7			-		
		[rpm]	540			-		
TLZ-21J								
		[HP] [kW]	23.9 - 39.9 17.6 - 29.4			-		
		[daNm]	58.1 - 73.6			-		
		[rpm]	540			1.46 - 1.92		
TLZ-292A								
		[HP] [kW]	64.9 47.8			-		
		[daNm]	155.5			-		
		[rpm]	540			1.86		
TLZ-301C								
		[HP] [kW]	89.7 - 114.8 66.0 - 84.5			-		
		[daNm]	232.0 - 274.0			-		
		[rpm]	540			1.60 - 2.42		



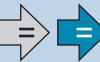

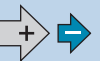





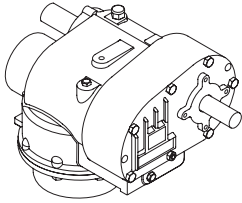

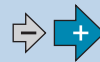

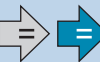

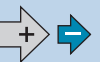
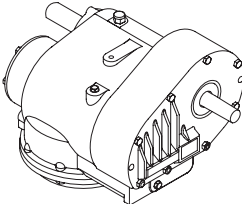

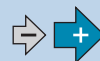

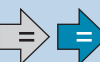



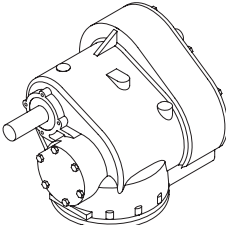



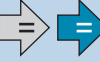



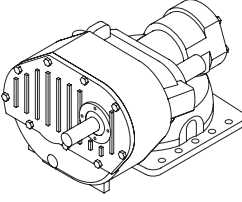



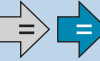

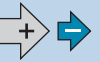
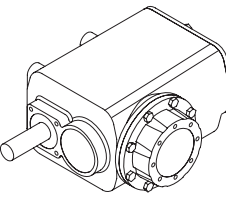

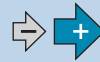

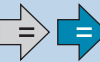
K-789C								
		[HP] [kW]	-			-	<input type="checkbox"/>	<input type="checkbox"/>
		[daNm]	19.0			-	<input type="checkbox"/>	<input type="checkbox"/>
		[rpm]	540			6.80		<input type="checkbox"/>
K-791A								
		[HP] [kW]	-			-	<input type="checkbox"/>	<input type="checkbox"/>
		[daNm]	19.0			-	<input type="checkbox"/>	<input type="checkbox"/>
		[rpm]	540			6.80		<input type="checkbox"/>
K-792A								
		[HP] [kW]	-			-	<input type="checkbox"/>	<input type="checkbox"/>
		[daNm]	19.0			-	<input type="checkbox"/>	<input type="checkbox"/>
		[rpm]	540			7.20		<input type="checkbox"/>
K-794A								
		[HP] [kW]	-			-	<input type="checkbox"/>	<input type="checkbox"/>
		[daNm]	21.0			-	<input type="checkbox"/>	<input type="checkbox"/>
		[rpm]	540			8.20		<input type="checkbox"/>
K-795A								
		[HP] [kW]	-			-	<input type="checkbox"/>	<input type="checkbox"/>
		[daNm]	23.0			-	<input type="checkbox"/>	<input type="checkbox"/>
		[rpm]	540			9.70		<input type="checkbox"/>
K-796A								
		[HP] [kW]	-			-	<input type="checkbox"/>	<input type="checkbox"/>
		[daNm]	23.0			-	<input type="checkbox"/>	<input type="checkbox"/>
		[rpm]	540			9.70		<input type="checkbox"/>

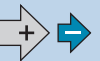
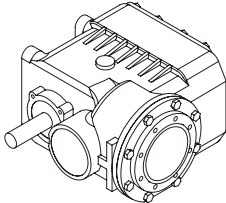

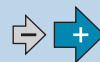







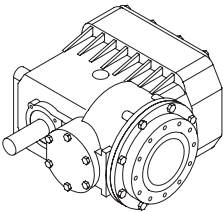

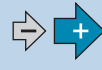



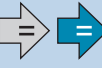



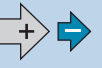

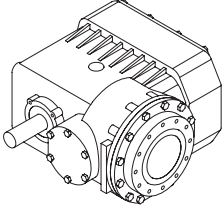









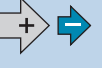

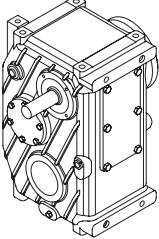

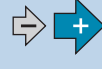
D-7B								
		[HP] [kW]	28.0 - 29.5 20.6 - 21.7			4.00 - 5.25	<input type="checkbox"/>	<input type="checkbox"/>
		[daNm]	6.7 - 9.3			-	<input type="checkbox"/>	
		[rpm]	540			-	<input type="checkbox"/>	<input type="checkbox"/>
D-21B								
		[HP] [kW]	55.0 - 56.0 40.5 - 41.2			2.95 - 4.53	<input type="checkbox"/>	<input type="checkbox"/>
		[daNm]	-			-	<input type="checkbox"/>	
		[rpm]	540			-	<input type="checkbox"/>	<input type="checkbox"/>
D-27B								
		[HP] [kW]	30.0 22.1			3.69 - 5.25	<input type="checkbox"/>	<input type="checkbox"/>
		[daNm]	-			-	<input type="checkbox"/>	
		[rpm]	540			-	<input type="checkbox"/>	<input type="checkbox"/>
D-732A								
		[HP] [kW]	80.0 58.9			-	<input type="checkbox"/>	<input type="checkbox"/>
		[daNm]	130.4 - 205.3			1.00	<input type="checkbox"/>	<input type="checkbox"/>
		[rpm]	540			1.93		<input type="checkbox"/>
D-741A								
		[HP] [kW]	-			-	<input type="checkbox"/>	<input type="checkbox"/>
		[daNm]	5.0			-	<input type="checkbox"/>	
		[rpm]	-			160.00	<input type="checkbox"/>	<input type="checkbox"/>
D-742A								
		[HP] [kW]	-			-	<input type="checkbox"/>	<input type="checkbox"/>
		[daNm]	200.0			-	<input type="checkbox"/>	
		[rpm]	-			116.00-756.00	<input type="checkbox"/>	<input type="checkbox"/>







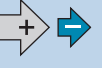



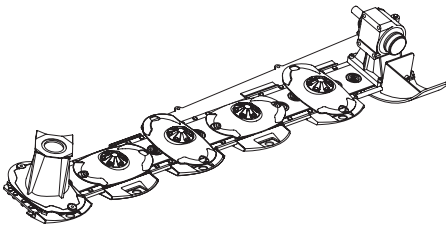

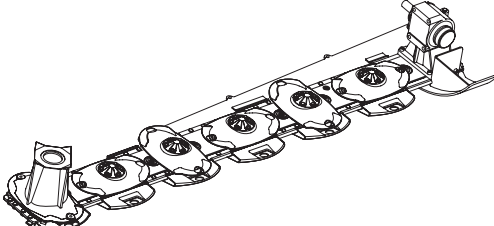
D-743A								
		[HP] [kW]	-			-	<input type="checkbox"/>	<input type="checkbox"/>
		[daNm]	25.0			-	<input type="checkbox"/>	
		[rpm]	-			97.00 - 631.00	<input type="checkbox"/>	<input type="checkbox"/>
D-744A								
		[HP] [kW]	-			-	<input type="checkbox"/>	<input type="checkbox"/>
		[daNm]	110.0			-	<input type="checkbox"/>	
		[rpm]	-			120.00-781.00	<input type="checkbox"/>	<input type="checkbox"/>
D-745A								
		[HP] [kW]	-			-	<input type="checkbox"/>	<input type="checkbox"/>
		[daNm]	60.0			-	<input type="checkbox"/>	
		[rpm]	-			117.00-766.00	<input type="checkbox"/>	<input type="checkbox"/>
D-825A								
		[HP] [kW]	298.9 220.0			-	<input type="checkbox"/>	<input type="checkbox"/>
		[daNm]	229.0 - 361.0			-		<input type="checkbox"/>
		[rpm]	1000			1.07 - 1.68	<input type="checkbox"/>	<input type="checkbox"/>
DV-733F								
		[HP] [kW]	179.8 132.3			-	<input type="checkbox"/>	<input type="checkbox"/>
		[daNm]	234.3 - 523.0			-		<input type="checkbox"/>
		[rpm]	1000			1.82 - 4.06	<input type="checkbox"/>	<input type="checkbox"/>
DV-813F								
		[HP] [kW]	70.0 51.5			-	<input type="checkbox"/>	<input type="checkbox"/>
		[daNm]	112.1 - 284.7			-		<input type="checkbox"/>
		[rpm]	540			1.21 - 3.06	<input type="checkbox"/>	<input type="checkbox"/>

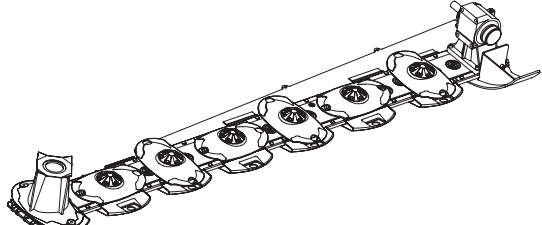
DV-818F									
		[HP] [kW]	94.8 69.8			-	<input type="checkbox"/>	<input type="checkbox"/>	
		[daNm]	156.7 - 402.4			-		<input type="checkbox"/>	<input type="checkbox"/>
		[rpm]	540			1.24 - 3.20	<input type="checkbox"/>	<input type="checkbox"/>	
DV-823F									
		[HP] [kW]	129.9 95.6			-	<input type="checkbox"/>	<input type="checkbox"/>	
		[daNm]	215.4 - 489.8			-		<input type="checkbox"/>	<input type="checkbox"/>
		[rpm]	1.000			1.25 - 3.02	<input type="checkbox"/>	<input type="checkbox"/>	
DZ-733F									
		[HP] [kW]	179.3 132.0			-	<input type="checkbox"/>	<input type="checkbox"/>	
		[daNm]	234.3 - 523.0			-		<input type="checkbox"/>	<input type="checkbox"/>
		[rpm]	1.000			1.82 - 4.06	<input type="checkbox"/>	<input type="checkbox"/>	
DZ-811F									
		[HP] [kW]	70.0 51.5			-	<input type="checkbox"/>	<input type="checkbox"/>	
		[daNm]	112.1 - 284.7			-		<input type="checkbox"/>	<input type="checkbox"/>
		[rpm]	540			1.21 - 3.06	<input type="checkbox"/>	<input type="checkbox"/>	
DZ-816F									
		[HP] [kW]	94.8 69.8			-	<input type="checkbox"/>	<input type="checkbox"/>	
		[daNm]	156.7 - 402.4			-		<input type="checkbox"/>	<input type="checkbox"/>
		[rpm]	540			1.24 - 3.20	<input type="checkbox"/>	<input type="checkbox"/>	
DZ-821F									
		[HP] [kW]	129.9 95.6			-	<input type="checkbox"/>	<input type="checkbox"/>	
		[daNm]	215.4 - 489.8			-		<input type="checkbox"/>	<input type="checkbox"/>
		[rpm]	1.000			1.25 - 3.02	<input type="checkbox"/>	<input type="checkbox"/>	

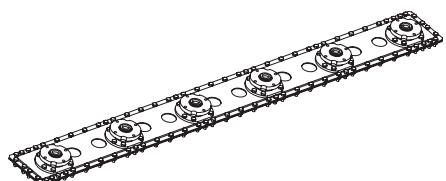

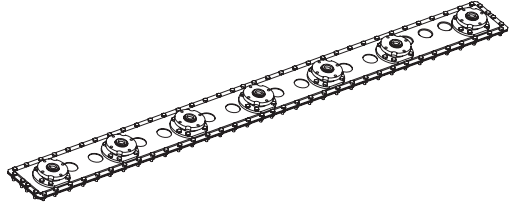
MV-814F									
		[HP] [kW]	70.0 51.5			-	<input type="checkbox"/>	<input type="checkbox"/>	
		[daNm]	112.1 - 284.7			-		<input type="checkbox"/>	<input type="checkbox"/>
		[rpm]	540			1.21 - 3.06	<input type="checkbox"/>	<input type="checkbox"/>	<input type="checkbox"/>
MV-819F									
		[HP] [kW]	94.8 69.8			-	<input type="checkbox"/>	<input type="checkbox"/>	
		[daNm]	156.7 - 402.4			-		<input type="checkbox"/>	<input type="checkbox"/>
		[rpm]	540			1.24 - 3.20	<input type="checkbox"/>	<input type="checkbox"/>	<input type="checkbox"/>
MV-824F									
		[HP] [kW]	129.9 95.6			-	<input type="checkbox"/>	<input type="checkbox"/>	
		[daNm]	215.4 - 489.8			-		<input type="checkbox"/>	<input type="checkbox"/>
		[rpm]	1.000			1.25 - 3.02	<input type="checkbox"/>	<input type="checkbox"/>	<input type="checkbox"/>
MV-826A									
		[HP] [kW]	199.7 147.0			-	<input type="checkbox"/>	<input type="checkbox"/>	
		[daNm]	373.1 - 456.0			-		<input type="checkbox"/>	<input type="checkbox"/>
		[rpm]	1.000			2.74 - 3.35	<input type="checkbox"/>	<input type="checkbox"/>	<input type="checkbox"/>
MZ-801F									
		[HP] [kW]	45.0 33.1			-	<input type="checkbox"/>	<input type="checkbox"/>	
		[daNm]	76.7 - 161.1			-		<input type="checkbox"/>	<input type="checkbox"/>
		[rpm]	540			1.29 - 2.73	<input type="checkbox"/>	<input type="checkbox"/>	<input type="checkbox"/>
MZ-812F									
		[HP] [kW]	70.0 51.5			-	<input type="checkbox"/>	<input type="checkbox"/>	
		[daNm]	112.1 - 284.7			-		<input type="checkbox"/>	<input type="checkbox"/>
		[rpm]	540			1.21 - 3.06	<input type="checkbox"/>	<input type="checkbox"/>	<input type="checkbox"/>

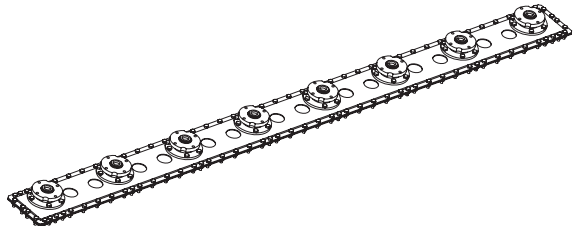
MZ-817F								
		[HP] [kW]	94.8 69.8			-		
		[daNm]	156.7 - 402.4			-		
		[rpm]	540			1.24 - 3.20		
MZ-822F								
		[HP] [kW]	129.9 95.6			-		
		[daNm]	215.4 - 489.8			-		
		[rpm]	1.000			1.25 - 3.02		
C-3A								
		[HP] [kW]	124.9 91.9			-		
		[daNm]	212.5 - 526.0			1.00		
		[rpm]	540			1.28 - 3.20		

FR-535A				
		[HP] [kW]	35.1 25.8	<input type="checkbox"/> <input type="checkbox"/> <input type="checkbox"/> <input type="checkbox"/>  <input type="checkbox"/>
FR-536A				
		[HP] [kW]	42.0 30.9	<input type="checkbox"/> <input type="checkbox"/> <input type="checkbox"/> <input type="checkbox"/>  <input type="checkbox"/>
FR-537A				
		[HP] [kW]	49.0 36.1	<input type="checkbox"/> <input type="checkbox"/> <input type="checkbox"/> <input type="checkbox"/>  <input type="checkbox"/>
FR-576A				
		[HP] [kW]	42.0 30.9	<input type="checkbox"/> <input type="checkbox"/> <input type="checkbox"/> <input type="checkbox"/>  <input type="checkbox"/>
FR-577A				
		[HP] [kW]	49.0 36.1	<input type="checkbox"/> <input type="checkbox"/> <input type="checkbox"/> <input type="checkbox"/>  <input type="checkbox"/>
FR-578A				
		[HP] [kW]	56.0 41.2	<input type="checkbox"/> <input type="checkbox"/> <input type="checkbox"/> <input type="checkbox"/>  <input type="checkbox"/>



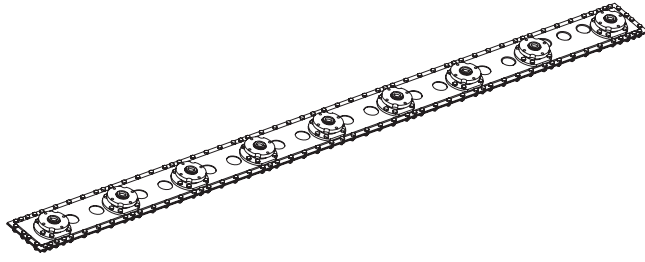





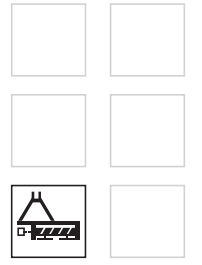

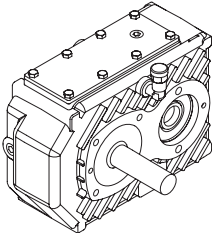



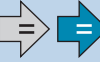

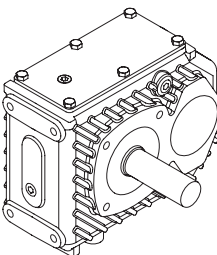







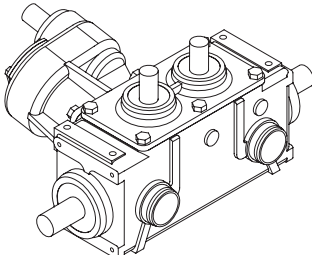



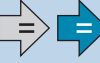

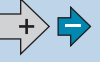
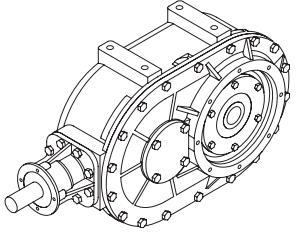

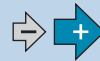
FR-579A



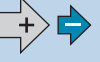
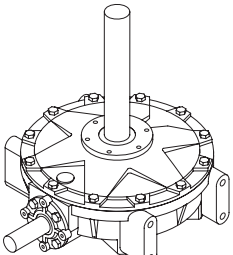

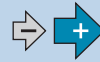



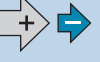

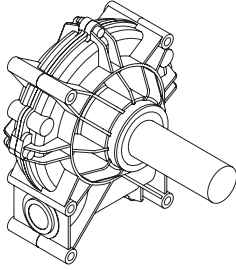





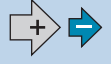
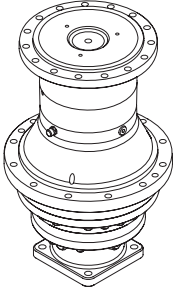



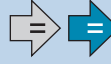

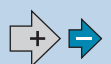
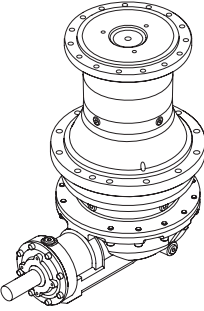



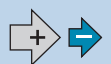
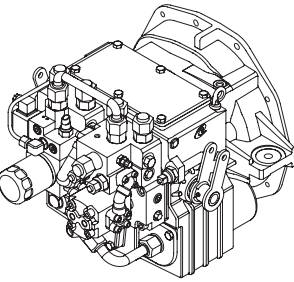

[HP]  
[kW]

62.9  
46.3



A640							
		[HP] [kW]	59.8 44			2.0 - 4.8	Decespugliatori Flail hedge mover
		[daNm]	15.7 - 37.8			-	
		[rpm]	540			-	
A649							
		[HP] [kW]	103.3 76			2.0 - 3.8	Decespugliatori Flail hedge mover
		[daNm]	25.2 - 47.9			-	
		[rpm]	540			-	
L170B							
		[HP] [kW]	12.0 8.8			-	Mietitrebbia Combined harvester
		[daNm]	-			-	
		[rpm]	-			-	
N673J							
		[HP] [kW]	74.9 55.1			-	Betoniera Concrete mixer
		[daNm]	1022			-	
		[rpm]	540			10.8	
L154J							
		[HP] [kW]	39.9 29.4			-	Betoniera Concrete mixer
		[daNm]	391			-	
		[rpm]	540			7.75	

SG450A							
		[HP] [kW]	-			-	Smonta gomme Tyre changer
		[daNm]	40			-	
		[rpm]	580			100	
PG1600							
		[HP] [kW]	-			-	Carro miscelatore Feed mixer
		[daNm]	1600			-	
		[rpm]	540			13.4 - 21.1	
PGA1600							
		[HP] [kW]	-			-	Carro miscelatore Feed mixer
		[daNm]	1600			-	
		[rpm]	540			13.4 - 21.1	
HT481							
		[HP] [kW]	33 25			-	Tosaerba Lawn mover
		[daNm]	-			-	
		[rpm]	3200			1,37 (P.T.O.)	

## Centro Ricerche di Meccatronica

### *Mechatronics R&D Centre*

#### Ricerca applicata ed innovazione di prodotto

Lo sviluppo, la sperimentazione e la prova dei prodotti GEARBOXES & DRIVESHAFTS vengono effettuati nel Centro Ricerche di Meccatronica di Comer Industries, realizzato nel 1996 a Reggiolo (RE) per la ricerca applicata e l'innovazione di prodotto.

Dal giugno 2002 il Centro Ricerche è inserito nell'albo dei laboratori di ricerca pubblici e privati gestito dal Miur, il Ministero italiano dell'Istruzione, dell'Università e della Ricerca, quale primo laboratorio in Italia operativo nel campo della meccatronica.

Il Centro Ricerche si estende su una superficie coperta di 1.500 mq., con undici celle di sperimentazione e prova, perfettamente insonorizzate, dotate di attrezzature all'avanguardia e di apparecchiature di simulazione in grado di riprodurre le situazioni di reale utilizzo e funzionamento delle trasmissioni sulla macchina operatrice.

Il Centro Ricerche consente a Comer Industries di realizzare l'innovazione, la messa a punto ottimale del prodotto e di comprimere i tempi di esecuzione dei prototipi; ai clienti consente di ridurre il time to market per il lancio sul mercato delle nuove macchine.

#### *Applied research and product innovation*

*GEARBOXES & DRIVESHAFTS product line is developed, tested and approved in the Comer Industries Mechatronics R&D Centre, which has been set up in 1996 at Reggiolo (RE) to conduct applied research and innovation.*

*At the end of June 2002, the Center has been introduced in the register of the Private and Public Research Laboratories run by the MIUR, the Italian Ministry of Instruction, University and Research. In the Mechatronic sector, The Comer industries' laboratory is the first in Italy to be included in the ministerial program.*

*The Mechatronics Centre operates on a covered area of 1500 sqm, with eleven test rooms, totally acoustic insulated equipped with the latest devices and simulators capable of reproducing machine operating environment.*

*The Centre enables Comer Industries to maximize innovation, the optimum product performances, to reduce the prototyping lead times and the customer's time-to-market required for innovative projects.*

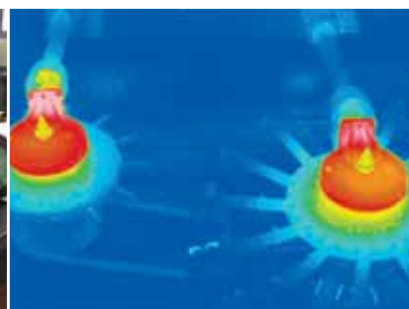













**comer industries**  
gearboxes

**Operating Unit Gearboxes & Driveshafts**  
42046 Reggiolo (RE) Italy - Via Magellano, 27  
Ph. +39 0522 974111- Fax +39 0522 973249  
**web site: [www.comerindustries.com](http://www.comerindustries.com)**